



For RC models Only for Futaba digital servo

Before using your new gyro, please read this manual thoroughly and use the gyro properly and safely. After reading this manual, store it in a safe place.

- No part of this manual may be reproduced in any form without prior permission.
- The contents of this manual are subject to change without prior notice.
- Futaba is not liable for any potential damage (accidental or otherwise) that may occur after installation.

Features of GYD550

● Dedicated RC Drift car setting

Vehicle straight-line and cornering performance can be increased without taking into account the effect of the road surface, etc.

● Remote gain function and mode switching function

You can adjust gain from the transmitter (3 or more CH) by using the remote gain function. The mode switching function allows AVCS/NORMAL gyro mode switching.

● Integrated, compact, and light weight

Compact size (22.6x19.6x11 mm) and light weight (5.6 g) realized by high density mounting technology.

● Aluminum case

The GYD550 is equipped with a robust and highly rigid aluminum case.

● Supporting the S.BUS/S.BUS2 connection

Only one wire connection to the receiver can operate the GYD550.

● Only for Futaba digital servo

Functions

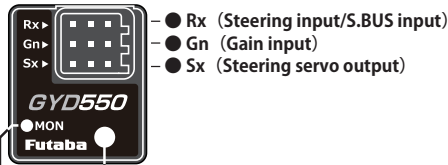

- Rx (Steering input/S.BUS input)
- Gn (Gain input)
- Sx (Steering servo output)

- LED
- Push Switch Press using the included mini screwdriver

Monitor LED display

| State | Color | Move | Reference |
|----------------------------------|-----------|------------|------------------------------|
| 1. No servo pulse / sensor error | Red | 2 flash | |
| 2. Warm-up | Green | Fast blink | |
| 3. Sensor initialization | Red/Green | ON | AVCS (Red) NORMAL (Green) |
| 4. Turn | Red/Green | Fast blink | Right (Green) Left (Red) |
| 5. Neutral offset | Orange | Slow blink | Steering operation |
| 6. Gain OFF | — | OFF | |
| 7. Low battery | Red | Blink | Less than 3.8 V |
| 8. Parameter settings | | | Indicated on the back page |

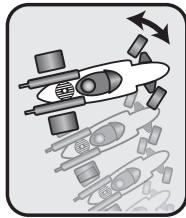

Thank you for purchasing the GYD550 RC cars gyro. Compact and lightweight, the GYD550 is designed to control steering for RC Drift cars. Features include S.BUS/S.BUS2 connectivity.

The transmitter needs 3 or more channels to control the gyro gain.

GYD550 Ratings:

(Integrated sensor type gyro)

- Gyro sensor: MEMS vibrating structure gyro
- Operating voltage: DC 3.5 V to 8.4 V
- Current drain: 30 mA (excluding a servo)
- Operating temperature range: -10 °C to +45 °C
- Dimensions: 22.6 x 19.6 x 11.0 mm (0.89 x 0.77 x 0.43 in) (except protrusion)
- Weight: 5.6 g (0.2 oz)
- Functions: LED monitor. Servo selection (SR mode). S.BUS/S.BUS2 connection.

Set Contents

The following items are supplied with the GYD550:

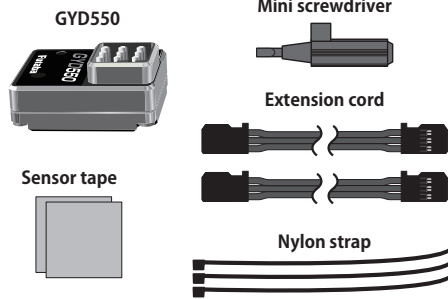

⚠ WARNING

Failure to follow these safety precautions may result in severe injury to yourself and others.

❗ Check that there is sufficient battery capacity.

- Do not operate the model and transmitter steering wheel for about 3-5 seconds after turning on the GYD550 (When shared with the receiver).

• GYD550 initialization and neutral position reading. The GYD550 is initialized when the power is turned on. The neutral position is also read at the same time. If initialization ends normally, the operator is informed by two repetitive movements of the servo to the left and right (a little).

❗ Always check the direction of operation of the gyro.

- Do not strike the gyro with a hard object. Do not drop it onto a concrete surface or other hard floor.

• The sensor may become damaged during strong impacts.

❗ Do not use trims or mixing.

• All corrections are made by the gyro. Therefore, if trimming and mixing, are turned on, operation will be the same as deviating from the neutral position.

❗ Do not use the GYD550 for applications other than RC cars.

• This gyro is designed for RC cars only. Do not use it for other applications.

❗ Analog servos cannot be used.

• The use of analog servos may cause servo trouble.

❗ Do not place gyro near heating equipment (engine, motor, ESC, battery, servo, etc.).

• Always allow the gyro to adjust to the surrounding environmental temperature before use. A large temperature change during use will cause drift and other operational issues.

Connecting the GYD550

*In SR mode, the transmitter steering channel and the gyro gain channel should be set to SR-ON.

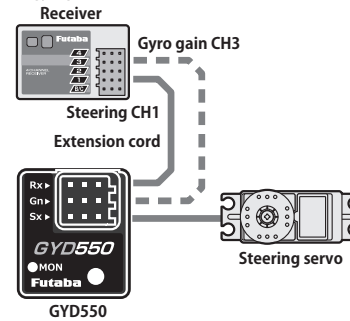

S.BUS Connecting the GYD550

* When using SR mode, S.BUS connection is not possible.

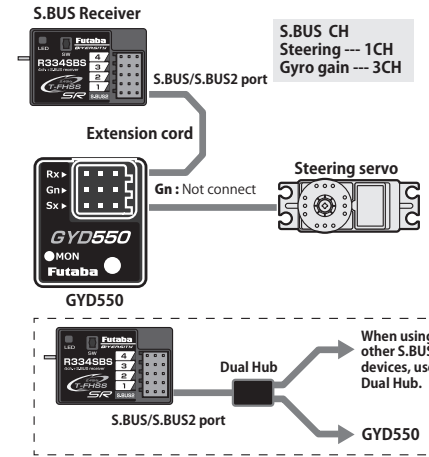

Mounting to Chassis

Use the included double-sided sponge tape to firmly attach the gyro perpendicular to the control axis, at a position where there is as little vibration as possible. Make the wiring loose and bundle it with the included nylon strap so that it will not interfere with the linkage rod.

Gyro mounting position

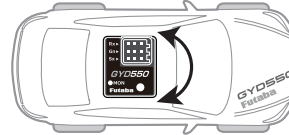

The direction of rotation fixed by the gyro can be any direction within 360° relative to the steering axis controlled by the gyro.

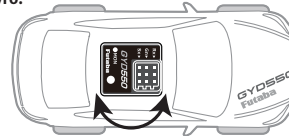

Flat surface of the chassis where the sensor tape sticks easily. Mount the gyro level so that it is not tilted relative to the chassis.

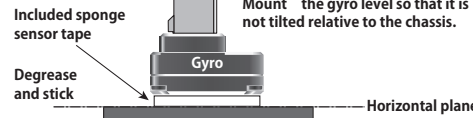

When GYD550 is turned ON

The GYD550 requires 3-5 seconds to initialize when the power is turned on. Do not move the car and do not move the steering wheel during this initialization or the gyro may not initialize properly. Once the initialization process has been completed the steering servo will move (a little) several times indicating that the GYD550 is now ready for use. If the neutral has shifted, LED will blink orange. In that case, it reboots.

Steering servo

Link the servo in accordance with the kit instruction manual.

When using S.BUS servo, initialize a parameter.

Make the servo operating range as wide as possible.

Make the numerical value of EPA (ATV) equal in left and right.

AVCS / NORMAL Modes

The gyro has 2 operating modes: NORMAL mode and AVCS mode. In the AVCS mode, gyro control is firmer. Because the feel of operation is different, choose your favorite mode.

NORMAL

The driver needs to perform counter-steer
⇒ Operation opposite to the turn direction



AVCS

Gyro performs countersteer
⇒ Steer in the turn direction.



SR mode

It is possible when using the T7PX(R), T7XC to change the servo to "SR Mode" and improve the servo response. If the servo can't be changed to SR mode, do not set the TX to SR mode.



Parameter settings

For GYD550, NORMAL/AVCS switching and gyro gain are performed by the transmitter. The settings on the main unit are the 5 items in the following table.

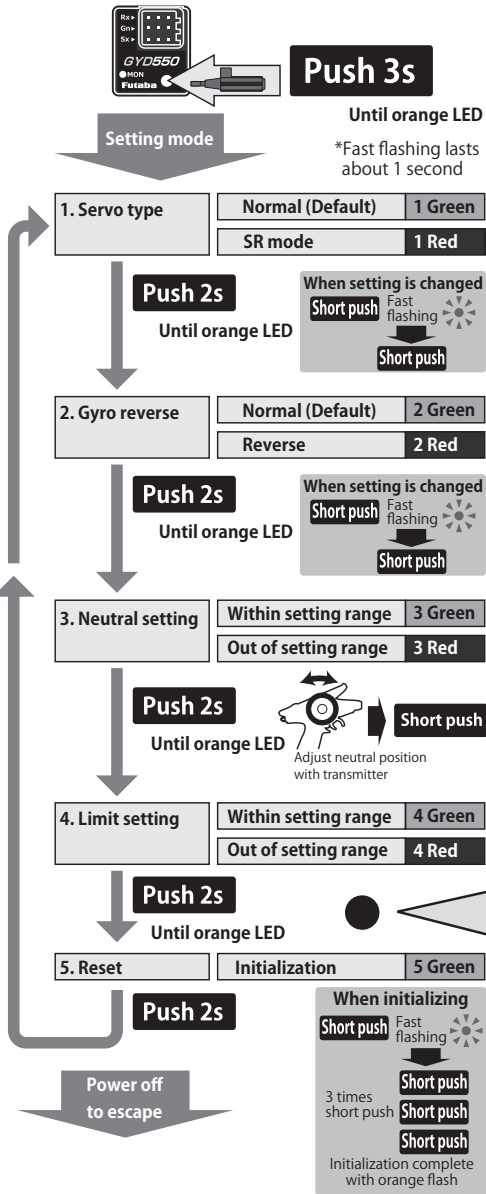

Wireless Settings

GYD550 can be wireless setting from T7PX(R)/T7XC and R334SBS/R334SBS-E. In that case, it is necessary to update T7PX(R)/T7XC and R334SBS/R334SBS-E to the version corresponding to GYD550 wireless setting. Refer to the version update manual for setting details.

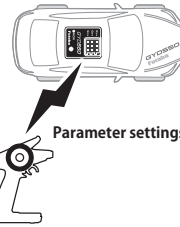

Limit Setting

Set the 4-Limit setting [LED blinks 4 times] according to the left figure.

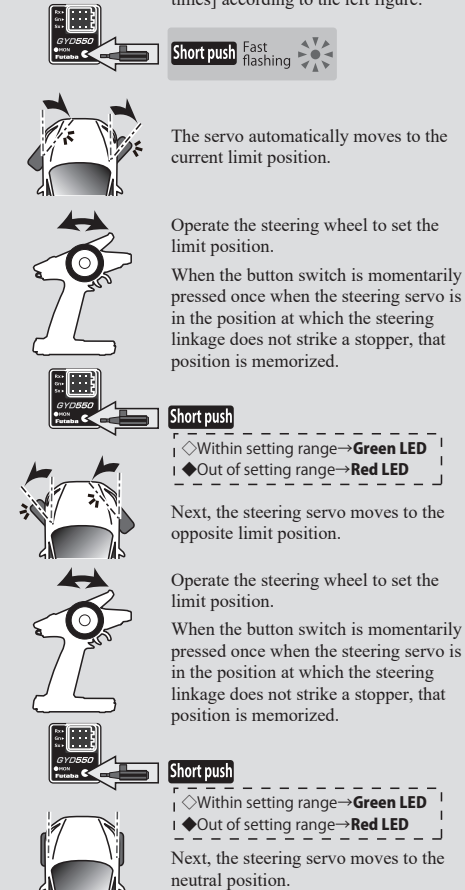

When setting is complete, the LED will blink 4 times. In this state, move the steering wheel and check if the limit positions are normal. (The servo operating angle moves 1.5 times the movement of the stick.) If there is any offset, press the button switch and repeat setting in both directions.

Damper (Hunting suppression)

The GYD550 can adjust the damper in 8 steps. Dampers reduce hunting and adjust steering feel. This damper can be set separately for NORMAL mode and AVCS mode.

Hunting → To Mild side

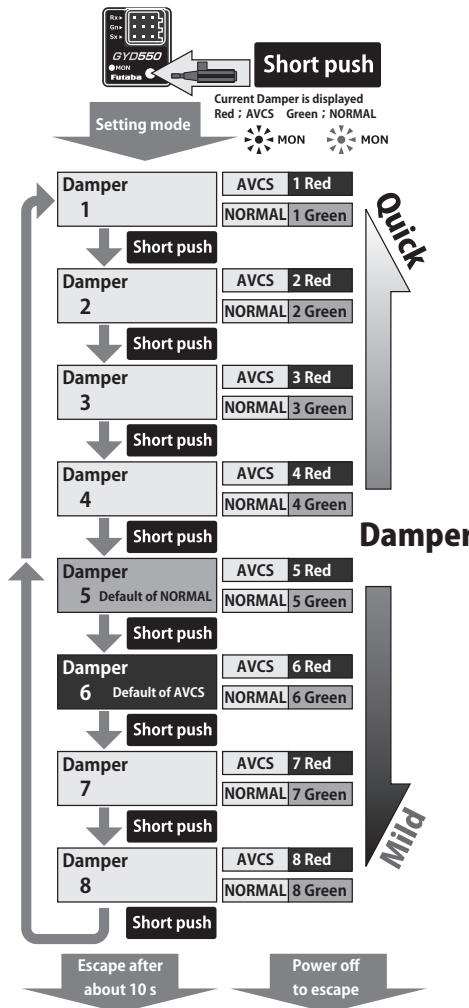

Gyro Gain and Mode Switching

When the remote gain function is used, NORMAL and AVCS mode switching is performed in accordance with the direction of operation of the transmitter's remote gain channel. At the + rate side, the AVCS mode is selected and at the - rate side, the NORMAL mode is selected. The sensitivity is changed by adjusting the end point rate. The sensitivity setting criteria by end point is shown in the figure below.

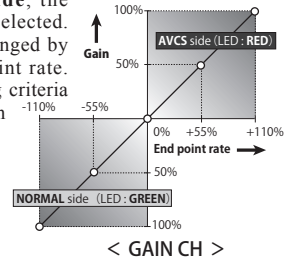

Setup before a run

Set the following GYD550 parameters according to the "Parameter Settings" section of this manual.

1. Servo type
2. Gyro reverse
3. Neutral setting
4. Limit setting

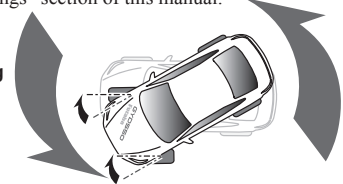

If the car is turned to the left by hand → steering goes out on the right

Turn on your transmitter's power. Set the gyro sensitivity to about 100% at the NORMAL or AVCS side in accordance with the transmitter instruction manual. Refer to the <GAIN CH> <AVCS / NORMAL Modes> graph.

| | |
|-----------------------|-----------|
| Gyro sensitivity zero | LED OFF |
| AVCS side | LED Red |
| NORMAL side | LED Green |

*Do not use transmitter trim and sub-trim. Make the neutral setting with a gyro.

Tuning Adjustment

By adjusting the gyro gain and Damper, you can adjust the holding power of the steering and the steering feeling. The setting we recommend is to drive at 70% gain and set the damper to the mild side if hunting occurs. The higher the gain, the greater the gyro effect, and the more hunting tends to occur.

FUTABA CORPORATION

1080 Yabutsuka, Chosei-mura, Chosei-gun, Chiba-ken, 299-4395, Japan
TEL: +81-475-32-6051, FAX: +81-475-32-2915

©FUTABA CORPORATION 2024, 4 (2)