

**Futaba**

**GYA 483**  
6-Axis Flight Control

**Instruction Manual**

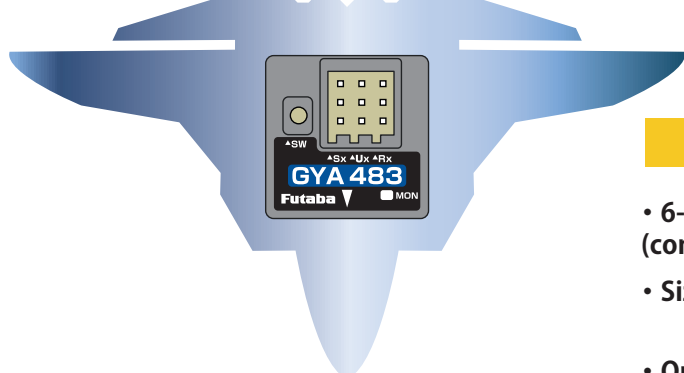

For models

**S.BUS 2**

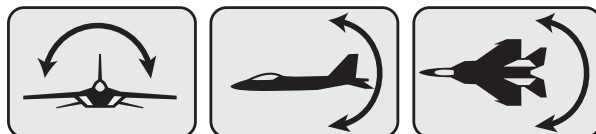

**GYA483 Ratings**

- 6-axis gyro for airplanes (compatible with electric and engine-powered aircraft)
- Size/Weight : 20.7 × 20.7 × 11.0mm / 3.7g (0.81 × 0.81 × 0.43 in / 0.13 oz)
- Operating voltage : DC3.8V ~ 8.4V
- Current drain: 30 mA (excluding a servo)
- 1-axis/2-axis/3-axis Switchable
- Output CH setting for each operation mode

**Set Contents**

① GYA483 × 1

② Double-sided tape × 2

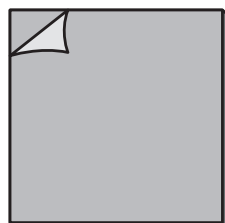
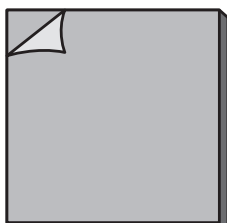
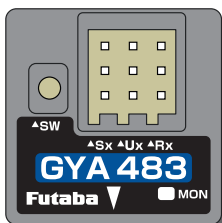

③ Receiver connection cable (Black) × 1



④ Receiver connection cable (Red) × 1



⑤ Mini driver × 1



⑥ Precautions × 1

**Each Part**

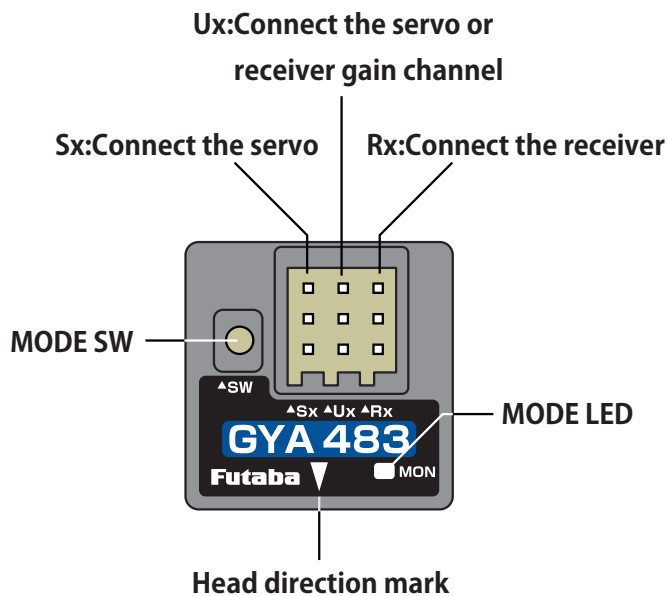

## Introduction

Thank you for purchasing the GYA483 airplane gyro. Compact and lightweight, the GYA483 is designed to control the ailerons (roll axis), elevators (pitch axis) and rudders (yaw axis). In addition, the GYA483 is equipped with a recovery mode to avoid danger. Features include simple set-up and S.BUS2 connectivity.

The GYA483 is an attitude control and stabilization device for model airplanes. In addition to control using a 3-axis gyro sensor, it also controls flight attitude using a 3-axis acceleration sensor. Three operating modes are available: 1-axis, 2-axis, and 3-axis. 1-axis mode allows operation equivalent to that of the GYA450/451. 2-axis mode allows a single unit to achieve elevons (delta wings) and V-tails, which previously required combining two GYA450/451 units. 3-axis mode uses S.BUS output, allowing functionality equivalent to the GYA483 to be used. This is a flexible airplane gyro that does not take up much mounting space.

## Features of GYA483

- 6-axis gyro for airplanes (compatible with electric and engine-powered aircraft)
- Size/Weight : 20.7 × 20.7 × 11.0mm / 3.7g (0.81 × 0.81 × 0.43 in / 0.13 oz)
- Operating voltage : DC3.8V ~ 8.4V
- Current drain: 30 mA (excluding a servo)
- 1-axis/2-axis/3-axis Switchable
- Output CH setting for each operation mode
- \*When using the GYA483, we recommend a transmitter with 10 channels or more and an S.BUS-compatible receiver.
- \*The GYA483's 3-axis mode uses S.BUS output. An S.BUS servo or an S.BUS signal converter such as the SBD-1/2 or DLPH-2/3 is required.

## Function

- Equipped with 3-axis angular velocity and acceleration sensors
- 6 aircraft mounting orientation options
- Switchable between 1-axis, 2-axis, and 3-axis operation modes
- 1-axis mode allows selection of AIL/ELE/RUD
- 1-axis mode allows standard channel input for control and gyro gain (equivalent to GYA450/451)
- 1-axis mode supports dual ailerons, dual elevators, and twin rudders when connected via S.BUS (equivalent to GYA450/451)
- 2-axis and 3-axis modes only support S.BUS input
- 2-axis mode allows selection of AIL/ELE, ELE/RUD, or AIL/RUD output channel combinations
- 2-axis and 3-axis modes support elevon (delta wing) and V-tail configurations
- 3-axis mode only supports S.BUS output (requires S.BUS servos or an S.BUS decoder)
- In 3-axis mode, you can select between S.BUS output and standard CH3 (THR) output.
- 3-axis mode allows gyro control of the 3rd AIL (AIL3) and 4th AIL (AIL4).
- Gyro gain can be set from the transmitter (remote gain setting).
- Recovery mode automatically returns the aircraft to a horizontal position if it loses orientation.
- Five operating modes: AVCS, Normal, Gyro Off, Auto Recovery, and Roll Flat can be switched from the transmitter.
- 4D flight compatible (see the 4D Pack website for settings).
- 3-axis mode, when used in combination with the DLPH-2/DLPH-3, allows for safe operation even with large aircraft requiring a robust power line.
- Basic settings such as operating mode and gyro reverse are controlled using the buttons and LED display on the unit.
- Detailed settings can be easily performed from the transmitter. (Compatible transmitters: T32MZ/WC, T26SZ/PRO, T16IZS)
- Air brake mixing (AIL/AIL2/AIL3/AIL4/ELE/EL2) settings available.
- \* Do not use simultaneously with the transmitter's air brake mixing.
- \* The actual servo movement amount will differ even if the same rate is set as the transmitter's air brake mixing.
- Camber mixing (AIL/AIL2/AIL3/AIL4/ELE/EL2) settings available
- \* Do not use simultaneously with transmitter camber mixing.
- \* The actual servo movement amount will differ even if the same rate is set as the transmitter's camber mixing.
- Compatible with FASSTest 26CH S.BUS input/output
- Roll Flat Function

With the aileron stick in neutral, the roll angle will be maintained horizontally within specified conditions (Note 1). This allows you to concentrate on elevator and throttle operation during landing, easing anxiety. It can also be used to practice maintaining a horizontal attitude during airborne flight.

Note 1 : When the pitch angle (elevator direction) is within  $\pm 60$  degrees and the roll angle is within the specified range.

## Servo selection

- Use Futaba S.BUS2 compatible servos.
- Servos that only support S.BUS or that do not support S.BUS/S.BUS2 cannot be used with S.BUS output in 3-axis mode.

## Precautions

- ❗ Check that there is sufficient transmitter battery capacity for flight.
  - Determine the operating time of the receiver, gyro, and servo battery in the adjustment stage and decide the number of flights with a margin to spare.
- ⊘ Do not operate the airplane and transmitter sticks for about 3 seconds after turning on the GYA483.
  - GYA483 initialization and neutral position reading. The GYA483 is initialized when the power is turned on. In the AVCS mode, the neutral position is also read at the same time. If initialization ends normally, the operator is informed by two repetitive movements of the servo to the left and right (a little).
- ❗ Always check the direction of operation of the gyro.
  - Attempting to fly with the operating direction reversed is extremely dangerous. Always check your gyro's direction to ensure safe flights.
- ⊘ Do not strike the gyro with a hard object. Do not drop it onto a concrete surface or other hard floor.
  - The sensor may become damaged during strong impacts.
- ⊘ Do not use trims or mixing in AVCS mode.
  - In the AVCS mode all corrections are made by the gyro. Therefore, if trimming and mixing, are turned on, operation will be the same as deviating from the neutral position.
- ❗ Analog servos cannot be used while in "digital servo" mode.
  - Analog servos may break down if "digital servo" mode is selected.
- ⊘ Do not use the GYA483 for applications other than RC airplanes.
  - This gyro is designed for RC airplanes only. Do not use it for other applications.
- ⊘ Do not place gyro near heating equipment (engine, motor, ESC, battery, servo, etc.).
  - Always allow the gyro to adjust to the surrounding environmental temperature before flight. A large temperature change during use will cause drift and other operational issues.
- ❗ Be sure to use the included double-sided tape when installing.
  - Using a different double-sided tape may cause malfunction.
- ⊘ Do not setting the transmitter while flying or while the engine or motor is running.
  - Unexpected movements during flight or while the engine or motor is running can be extremely dangerous.
- ❗ Gyro control is not possible during a stall.
- ⊘ Do not set the transmitter failsafe function on a channel using the gyro.
- ❗ The GYA483 can only be used in combination with Futaba products.
- ❗ The GYA483 requires an S.BUS receiver.
- ❗ For the GYA483, use Futaba S.BUS2 compatible servos.
- ❗ Servos that only support S.BUS or that do not support S.BUS/S.BUS2 cannot be used with S.BUS output in 3-axis mode.

## Mounting to the Airplane

Firmly stick the gyro to the fuselage with the double sided tape supplied. Install the gyro at a level place near the center of gravity where there is little vibration. It can also be installed at the side or rear of the fuselage. In this case, change the gyro mount direction setting.

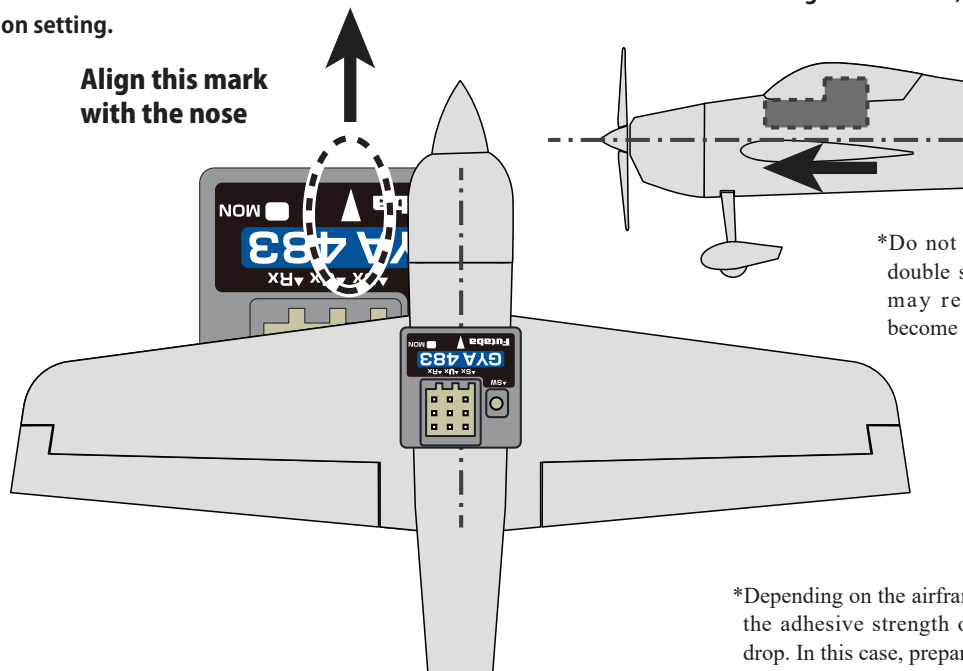

\*Depending on the airframe material such as balsa, etc., the adhesive strength of the double sided tape may drop. In this case, prepare the mounting surface well.

# Connection

## Example of PWM connection for aileron 1-axis

- Set the operating mode to **1-axis mode**
- Set the Sx output to **AIL**

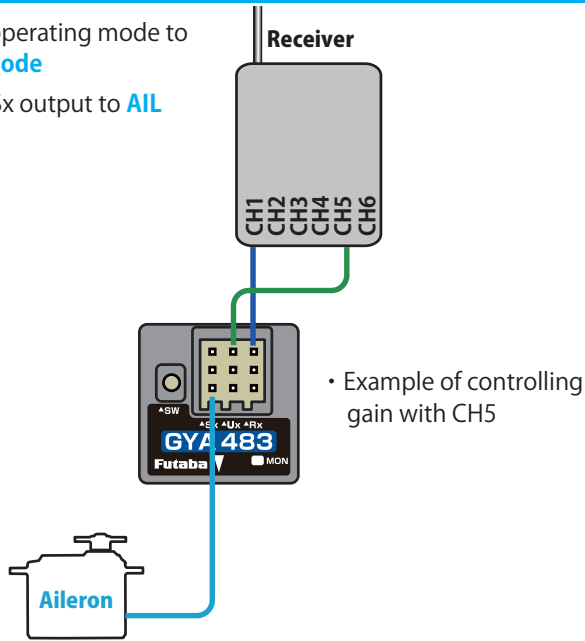

## Example of S.BUS connection for aileron 1-axis

- Set the operating mode to **1-axis mode**
- Set the Sx output to **AIL**

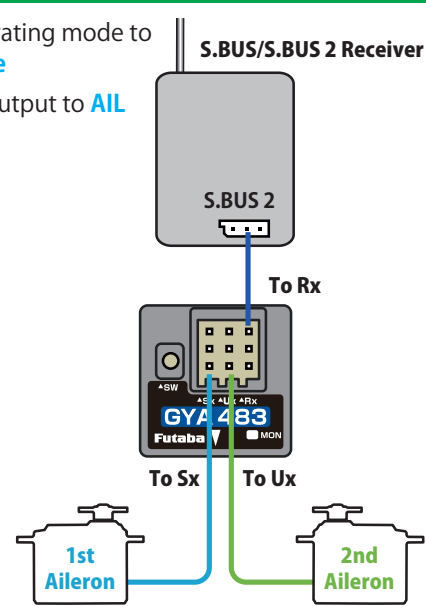

## Example of connecting to aileron and elevator using 2-axes

- Set the operating mode to **2-axis mode**
- Set the Sx output to **SX → AIL**
- Ux → ELE**

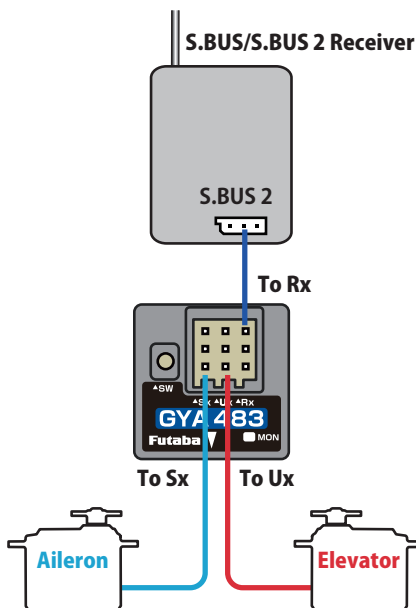

## Example of S.BUS2 connection using 3-axes

- Set the operating mode to **3-axis mode**
- Set the Sx output to **SX → S.BUS**
- Ux → S.BUS**

\*It is necessary to set CH of S.BUS/S.BUS2 servo.

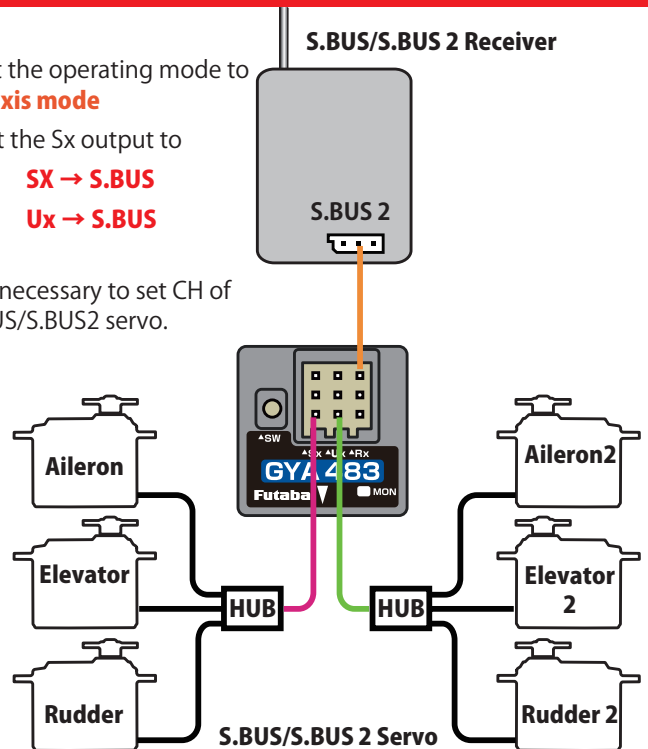

- Connect to S.BUS/S.BUS2 using the receiver connection cable.
- Set the transmitter channel as follows:

CH1	Aileron
CH2	Elevator
CH4	Rudder
CH5	Aileron Gain
CH6	Aileron 2
CH7	Elevator Gain
CH8	Rudder Gain
CH9	Elevator 2
CH10	Recovery Mode ON/OFF
CH11	Rudder 2

## Servo installation

Linkage the servo in accordance with the kit instruction manual.  
Adjust the linkage rod so that the trim amount is as small as possible.

### 2nd servo operating direction

During aileron mode operation the 2nd aileron servo moves in the same direction as the aileron servo. In the elevator mode, the 2nd elevator servo moves in the opposite direction of the elevator servo. Mount the servos as left and right symmetrical linkage.

### Digital/Analog servo selection

Selection of an analog and digital servo is performed in a parameter settings.

Parameter Settings: 3. Servo type is as follows.

Digital servo → DG : 285 Hz      Analog servo → AN : 70 Hz

The stability of digital-servo mode of a flight increases in order to perform a high-speed control action.

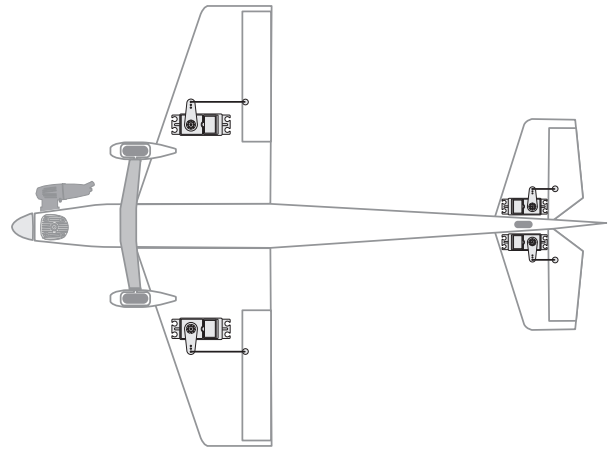

ⓘ When you use an analog servo, please be sure to set to AN : 70 Hz. If it sets to DG : 285 Hz and it is operated, there is a danger that a servo will be destroyed.

## ELEVON/V-TAIL Connection

Set with the wing type of GYA483. The wing type of the transmitter is not used and is normal.

- Turn off (INH) the elevon / V-tail mixing (Wing type) on the transmitter side.
- Do not use transmitter sub-trim. Adjust using the gyro neutral offset.
- When using the S.BUS servo, you can also use the neutral offset function of the S.BUS servo setting parameters.

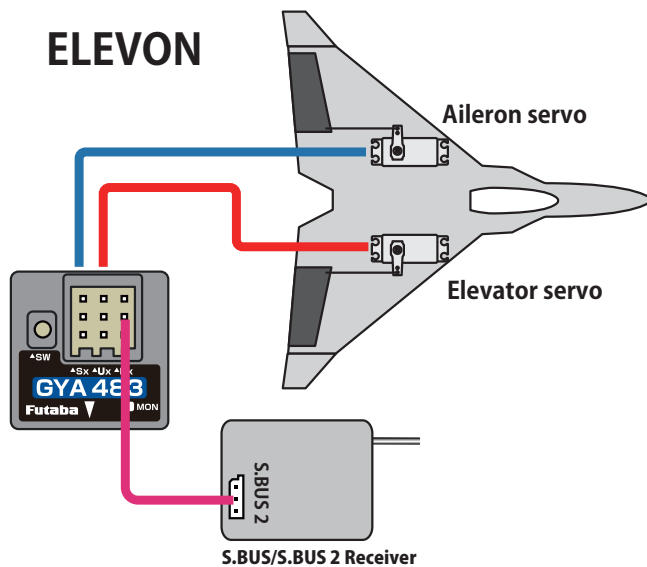

- Set the wing/type to **ELEVON**
- Set the operating mode to **2-axis mode**
- Set the Sx output to  
**SX → AIL**  
**Ux → ELE**

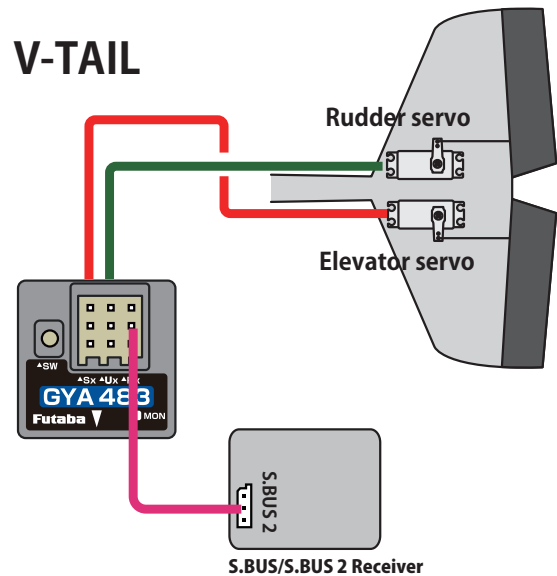

- Set the wing/type to **V-Tail**
- Set the operating mode to **2-axis mode**
- Set the Sx output to  
**SX → ELE**  
**Ux → RUD**

## GYA483 Start up time

When the GYA483 is started, it takes 6 to 7 seconds to accurately grasp the attitude of the aircraft. During that time, do not move the aircraft by fixing it at an inclination of 30° or less horizontally. If it is tilted by 30° or more, a startup error will occur and the LED will blink red. In this case, return the aircraft to the horizontal position. GYA483 will restart when it is returned to the horizontal position. Fix the aircraft within 30° horizontally even when restarting.

## Servo Operation on the Ground

If the stick is moved when the airplane is on the ground, the servo will move to the limit position. In the AVCS mode, the servo will not return to the neutral position even if the stick is set to the neutral position, but this is normal.

If the stick is moved fully to the left or right three or more times within one second, the servo will temporarily return to the neutral position.

## Monitor LED display

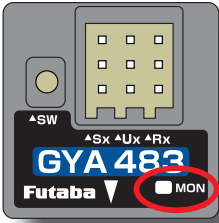

	State	LED	Reference
1	No signal	1-axis : 1 red flash 2-axis : 2 red flash 3-axis : 3 red flash	
2	Warm-up	Fast blinking Green	
3	After initialization	Green	
4	Receive error	Red	
5	Recovery mode ON	1 green flash	
6	Roll Flat ON	2 green flash	Only the switch is ON
7	Roll-flat operation in progress	3 green flash	
8	Low Battery	Slow blinking red	Less than 3.8 V
9	Memory Error	Red-Green blink	
10	Parameter Settings	See the parameter setting section	

## Gyro Sensitivity and AVCS Switching

The gyro has two operation modes: NORMAL mode and AVCS mode.

**In the AVCS mode**, angle control is performed at the same time as NORMAL mode rate (rotating speed) control. **In the AVCS mode**, the neutral keeping force is stronger than the NORMAL mode and the flight attitude of the aircraft is forcefully maintained. During knife-edge flying, the bending of the roll and pitch axes is corrected. On the other hand since the rudder follows when the aircraft stalls, pay special attention to the elevator axis. To be safe, switching to the NORMAL mode when taking off and landing is recommended. When the remote gain function is used normally and AVCS mode switching is performed in accordance with the direction of operation of the transmitter's remote gain channel. At the + rate side, the AVCS mode is selected and at the - rate side, the NORMAL mode is selected. The sensitivity is changed by adjusting the end point rate. If the transmitter has a gyro sensitivity setting mixing function, the sensitivity setting is performed directly. The sensitivity setting criteria by end point is shown in the figure below. The sensitivity becomes zero between end point -50% to +50% and becomes 100% at end point 130%.

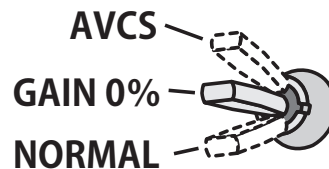
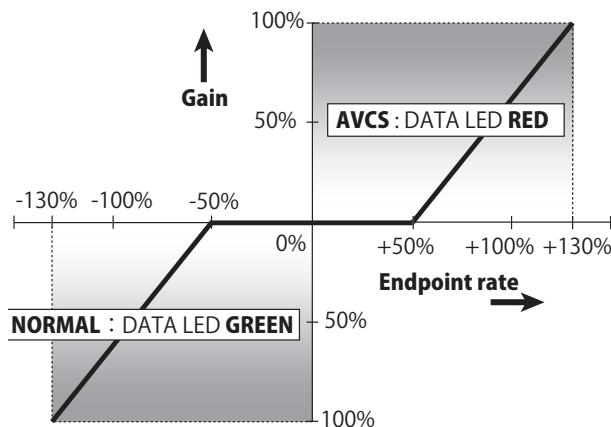

When AVCS is used we recommend that the sensitivity CH be set to the 3-position.

Refer to the transmitter instruction manual and set the end point. When AVCS is used, setting the 3-positions switch to the sensitivity CH (there are types which cannot be set by transmitter) and setting it as shown above is recommended. In the case of a 2-positions switch, inhibiting the gyro at 0% sensitivity such as NORMAL mode and sensitivity 0% and AVCS mode and 0% sensitivity is safe.

# Parameter Settings

First, be sure to set the following items if they are different from the default settings.

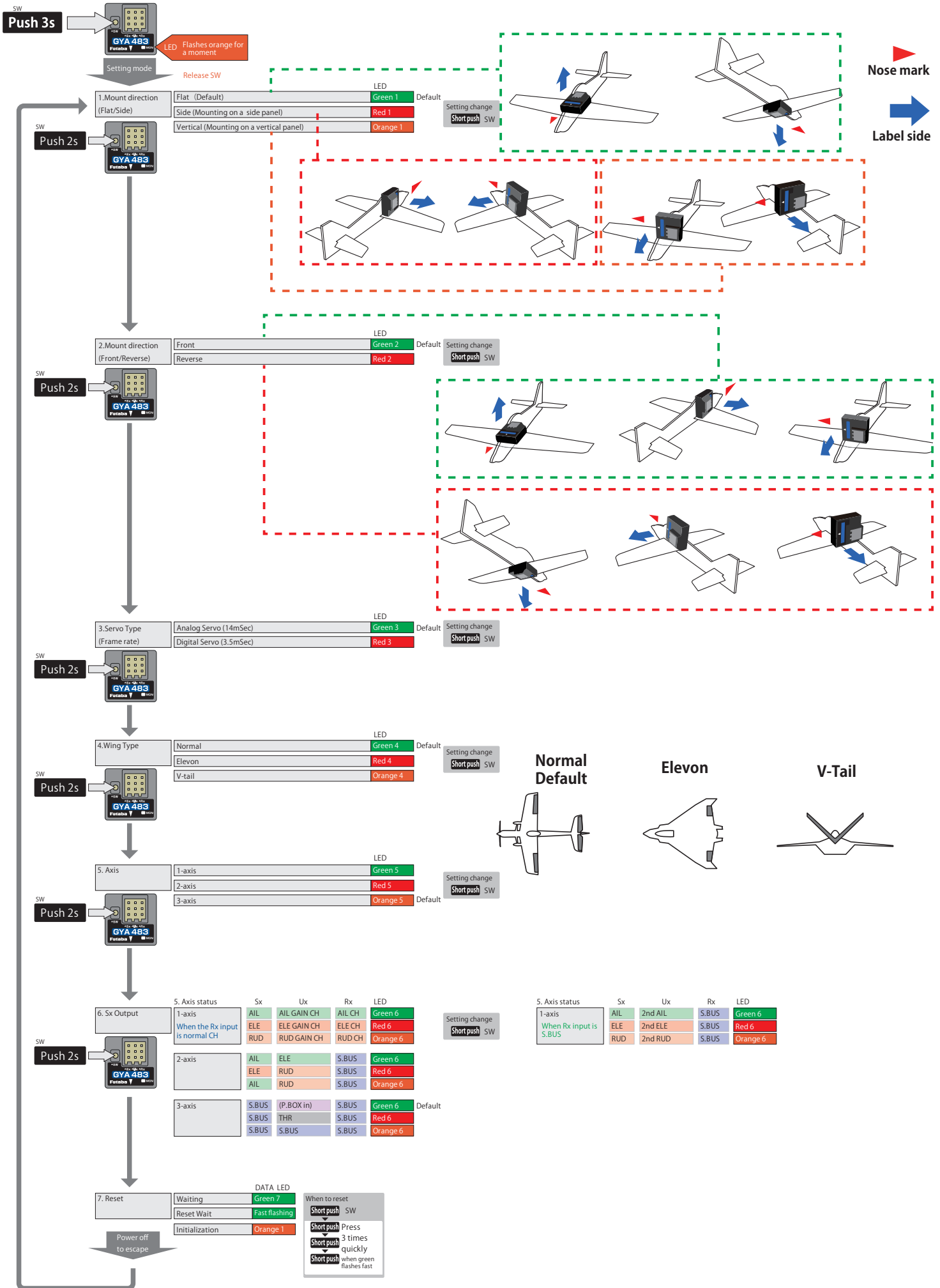

# Gyro reverse

It is the direction setting of the gyro. Set each of the three axes. Be careful as it will crash if the direction is reversed.

For dual aileron, dual elevator, and dual rudder aircraft, check the operating direction of each second aileron/elevator/rudder.

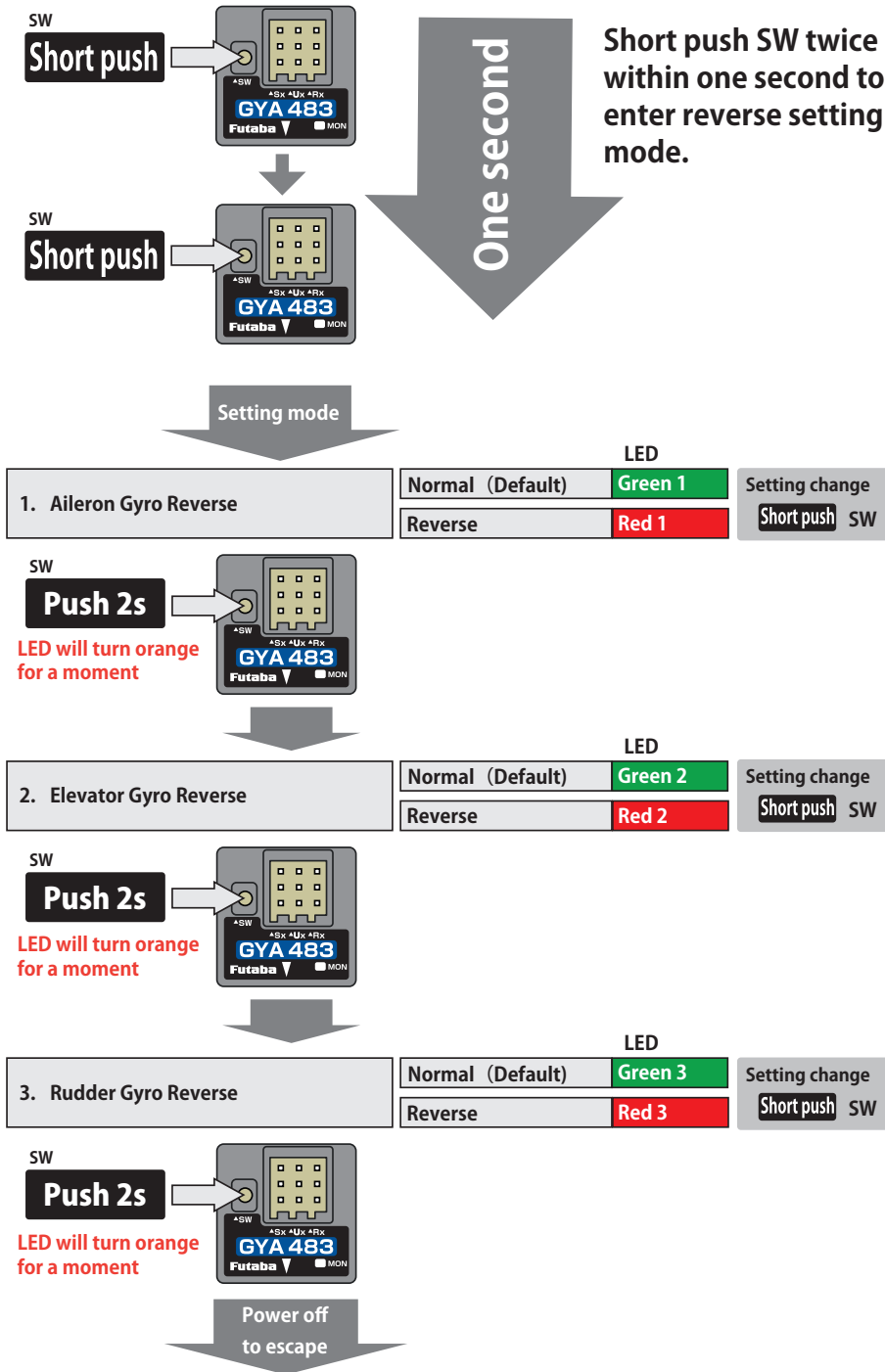

Tilt the airplane to the left on the ground and check that the ailerons operate to the right.

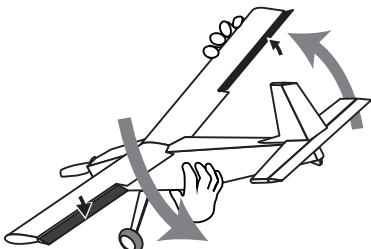

Raise the airplane with its nose upward and check that the elevator operates downward.

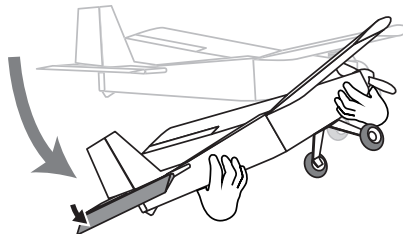

Turn the airplane to the right on the ground and check that the rudder operates to the left.

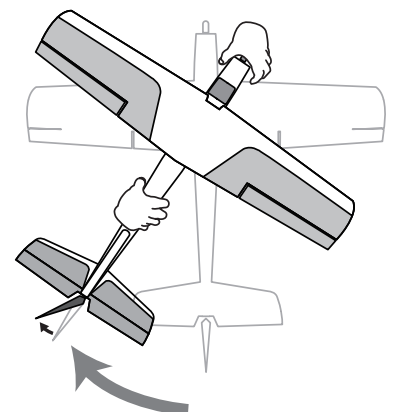

## GYA483 settings from the transmitter or program box

Connect the separately sold gyro program box GPB-1 to the Ux port of GYA483, you can set the parameters of GYA483 in the program box. However, GPB-1 needs to be updated for GYA483 from the Futaba website. (CIU-3 / 2 is required) For details, refer to the Futaba website.

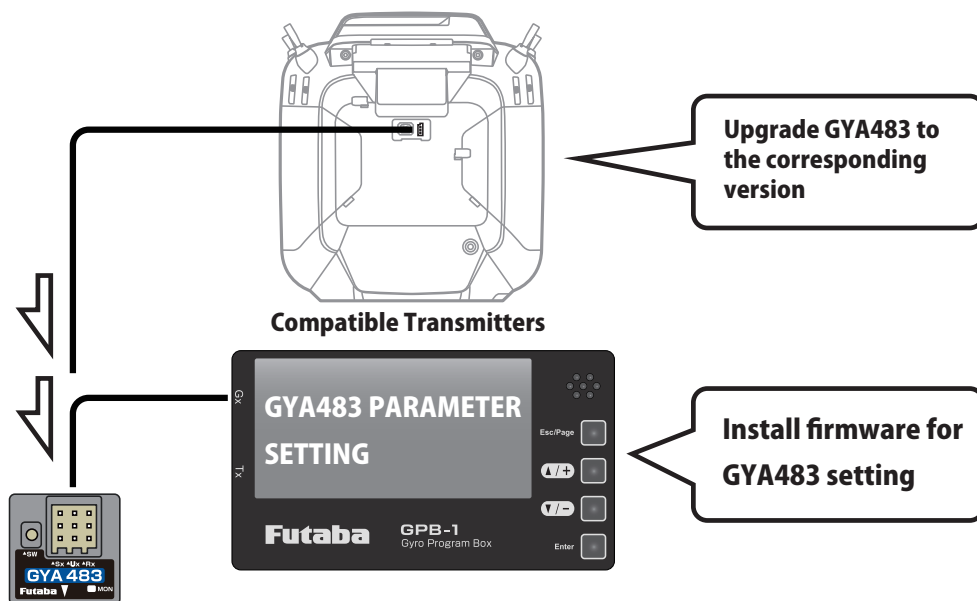

The GYA483 will only recognize the connection of a transmitter or GPB-1 immediately after powering on. Do not connect the transmitter or GPB-1 while the GYA483 is operating, as this may cause a malfunction.

## Recovery mode (Set with a compatible transmitter or GPB-1)

By turning on the recovery switch (initial setting CH10) of the transmitter, it is possible to automatically return to level flight. It is used in the unlikely event that you lose track of the direction of the aircraft. NORMAL / AVCS / GYRO OFF Recovery mode starts in any state.

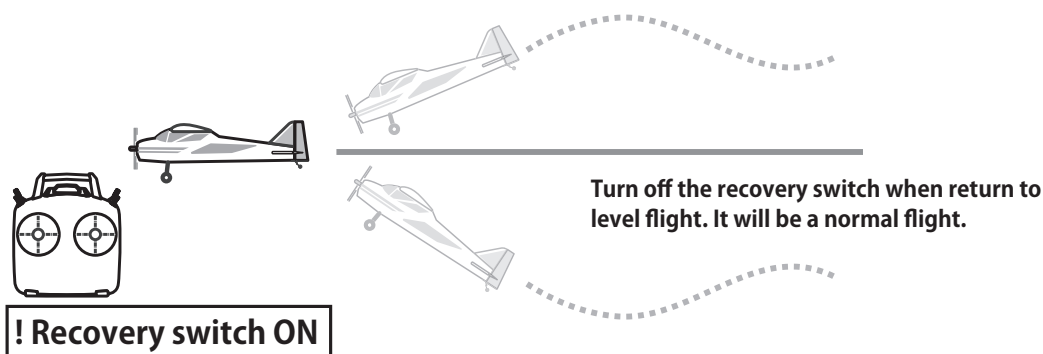

Maneuvering is possible even when the recovery switch is ON, but the operation differs as follows.

- When the recovery switch is ON, release the stick to neutral and the aircraft will be in level flight.
- When the recovery switch is ON, the roll and pitch tilt angle is limited to 70 ° when the transmitter travel rate is 100%. Inverted flight is not possible. Decreasing the travel rate of the transmitter will reduce the maximum tilt angle of the aircraft. The maneuvering feels dull and the turning radius increases. If the recovery switch is turned off when turning, the operation will suddenly take effect and the aircraft will tilt and become dangerous. Turn off the recovery switch when the stick is in neutral.
- When the recovery switch is ON, the LED 1 flashes green.
- A momentary type switch is recommended for the recovery mode.

## Air Brake (Set with a compatible transmitter or GPB-1)

This function is the same as the air brake function of the transmitter. Two rates, A1 and A2, can be set.

(The amount of operation is slightly less than that of the air brake function of the transmitter. It can also be used in AVCS mode where the air brake function of the transmitter cannot be used.)

Roll Flat function works even when the air brake is on.

## Camber mixing (Set with a compatible transmitter or GPB-1)

This function is equivalent to the camber mixing function of the transmitter.

It can also be used in AVCS mode where the transmitter's camber mixing function cannot be used.

## Roll Flat (Set with a compatible transmitter or GPB-1)

This function keeps only the roll axis horizontal (roll angle  $0^\circ$  ).

When used during landing approach, it keeps the roll axis horizontal, making aileron operation easier and allowing you to concentrate on throttle and elevator operation, making landing easier. It also maintains horizontality during inverted flight. The roll angle at which the roll flat function turns on should be set to  $10^\circ$  to  $15^\circ$  during landing, and  $15^\circ$  to  $20^\circ$  during normal flight, for a smooth flight.

Conditions for the roll flat function to be ON (when all of the following conditions are met)

- 1) Roll Flat Switch Channel is set (not INH)
- 2) When the roll flat switch channel is in the - position from neutral when viewed on the transmitter AFR setting screen.
- 3) When the roll flat switch channel operation position is viewed on the AFR setting screen of the transmitter, when the rate value is  $Wp$  (%), the roll angle of the aircraft is within  $Wp/2$  (degrees).
- 4) When the aileron stick is in the neutral position.
- 5) When the aircraft pitch angle is  $\pm 60^\circ$  or less

[EX.] When the roll flat switch channel is CH15, if the operating position of CH15 is the AFR rate -50%, the roll angle at which the roll flat function will be turned ON will be within  $\pm 25^\circ$

When the Roll Flat Switch Channel is set to an AFR rate of -100% or less, the auto recovery mode operates.

\*For detailed settings, refer to the setting manual of compatible transmitter or GPB-1 update manual on the Futaba WEB site.

# Flight Adjustment

Adjust the transmitter and gyro while repeatedly taking off and landing and with the aircraft on the ground.

**⚠** Transmitter adjustments must not be made while flying because it is dangerous.

**1.** Fly the plane and adjust the trim with GAIN 0% or NORMAL.

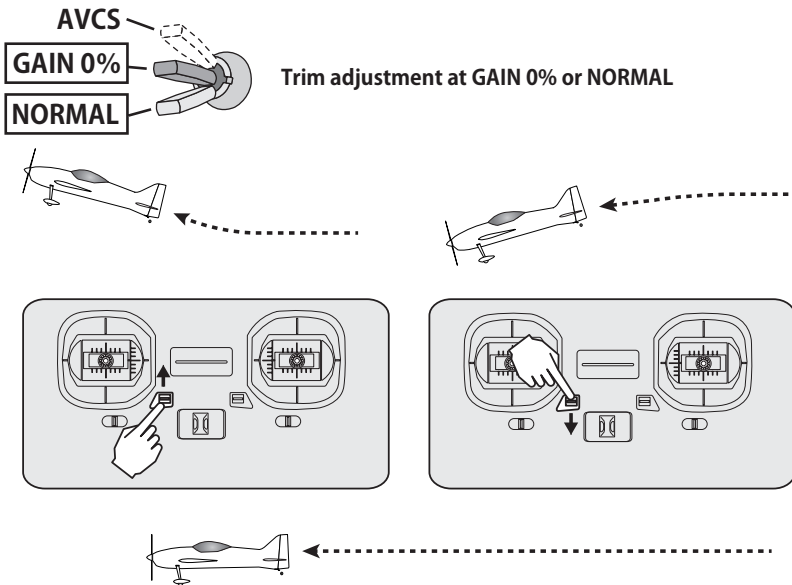

**2.** After trimming, switch the gain switch between 0% sensitivity (or NORMAL mode) and the AVCS mode three times at an interval of within one second and then set the gain switch to the AVCS mode position. This memorizes the AVCS mode neutral trim position at the gyro. In the AVCS mode, do not perform trimming during flight.

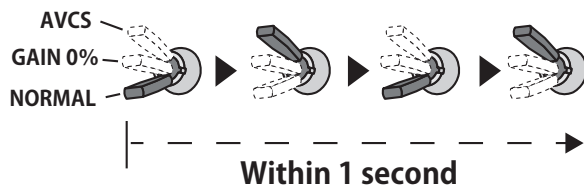

**3.** Adjust the gyro sensitivity so that hunting (deflection of the aircraft in small increments) does not occur in the control axis direction. The gyro sensitivity is different depending on the area of the aircraft rudder, air speed, and gyro used. Initially try changing the sensitivity in 5% steps. If hunting is excessive, the aircraft may be damaged. Hunting tends to stop when the airspeed is lowered.

## **⚠** WARNING

**⊘ Do not operate trim in AVCS mode. No mixing is used in AVCS mode.**

- In AVCS mode, all corrections are performed by the gyro. Therefore, turning on trim operation or mixing will result in the same behavior as neutral deviation.

**⊘ Do not set up the transmitter during flight or while the engine or motor is running.**

- Unexpected movements during flight or while the engine or motor is rotating can be extremely dangerous.

## GYA483 Update

GYA483 can be updated from a PC by connecting the separately sold CIU-3 / 2. Please check the Futaba dealer in your country website for the latest firmware and update method.

<https://futabausa.com/>

FUTABA CORPORATION

1080 Yabutsuka, Chosei-mura, Chosei-gun, Chiba-ken, 299-4395, Japan  
TEL: +81-475-32-6051, FAX: +81-475-32-2915